

ILD1000G Installation Handbook

Handbook Contents

- Safety
- Introduction
- Quick Start
- Installation
- Overview
- Troubleshooting
- Accessories
- Technical Specifications
- Warranty
- Declaration Of Conformity

Box Contents

- 1 x ILD1000G
- 1 x Loop connector
- 1 x Status socket connector
- 1 x 'Installation Handbook'
- 2 x 1U Rack mounting ears
- 1 x Power cable
- 1 x Deaf logo





This symbol is used to alert the user to important operating or maintenance instructions.



The Lightning bolt triangle is used to alert the user to the risk of electric shock.

SAFETY

1. It is important to read these instructions, and to follow them.
2. Keep this instruction manual in an accessible place.
3. Clean only with a dry cloth. Cleaning fluids may effect the equipment.
4.  Do not block any ventilation openings. Install in accordance with the manufacturer's instructions.
5. Do not install this equipment near any heat sources such as radiators, heating vents or other apparatus that produces heat.
6.  **WARNING – THIS APPARATUS MUST BE EARTHED / GROUNDED.**
7. Only power cords with the correct power connector may be used to maintain safety. Cables incorporating the UK 13A fused plug, Schuko with earthing contacts and UL approved "grounding type" are acceptable. These must be plugged into power outlets which provide a protective earth.
8. Refer all servicing to qualified personnel. Servicing is required when the apparatus has been damaged in any way, such as a power supply cord or plug is damaged, liquid has been spilled or objects have fallen into the apparatus, the apparatus has been exposed to any rain or moisture, does not operate normally or has been dropped.
9.  **WARNING – To reduce the risk of fire or electric shock, do not expose this apparatus to rain or moisture. The apparatus shall not be exposed to dripping or splashing and no objects filled with liquids, such as vases, shall be placed on the apparatus.**



CAUTION
RISK OF ELECTRIC SHOCK
DO NOT OPEN

TO PREVENT ELECTRIC SHOCK DO NOT REMOVE THE COVER. THERE ARE NO USER SERVICEABLE PARTS INSIDE. REFER SERVICING TO QUALIFIED PERSONNEL.

INTRODUCTION

The ILD1000G Induction loop driver has been designed as a high quality amplifier for use with conference rooms, stadia, theatres, sports halls, confidential rooms, lecture halls and cinemas. Depending on a number of factors regarding the installation of the loop and the set-up of the amplifier the ILD1000G can provide compliance with IEC60118-4 for areas >1300m².

Ease of installation and use have been major factors in the design, combined with optimised performance, and the freedom from R.F.I. generation.

The ILD1000G has three inputs. A balanced line (INPUT 3), a balanced microphone (INPUT 1) and one (INPUT 2) which can be configured to either. For more complex installations, you may need ancillary equipment such as microphone pre-amplifier(s), adaptor(s) for use with 100V line, or signal processing units. See **Accessories** or contact Ampetronic for advice.

QUICK START

For those who have a good appreciation of loop systems, the following is a very quick guide to setting up the amplifier: All you need is an ac power source, a signal source and a loop. See 'Designing Induction Loops' handbook (supplied) or contact Ampetronic for advice.

Installation

1. Turn all controls fully anti-clockwise.
2. Connect loop cable of appropriate length / gauge.
3. Connect signal input(s).
4. Connect power. See points 6 and 7 in **SAFETY** section.
5. If rackmounted remove all rubber feet from units. DO NOT re-fit the feet fixing screws as this may cause damage and invalidate the warranty

Operation

6. Switch ON – check green POWER LED flashes during self test and illuminates continuously when checks are complete.
7. Apply input signal and increase the input control until two green COMPRESSION LEDs are illuminated on the peaks of the signal.
8. Adjust the CURRENT control until the CURRENT LED illuminate to achieve the desired peak current.
9. Repeat step 6 for any other inputs used.
10. Listen to the magnetic field produced inside the loop area using a receiving device (e.g. Ampetronic ILR3), or examine the performance in more detail with a field strength meter.
11. Adjust MLC control to achieve a flat frequency response.

Connections

INPUT 1 & 2

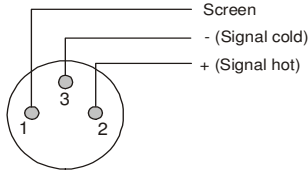

Connection of balanced male XLR

INPUT 3

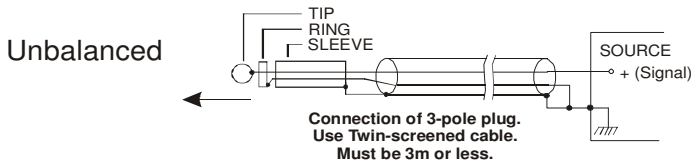
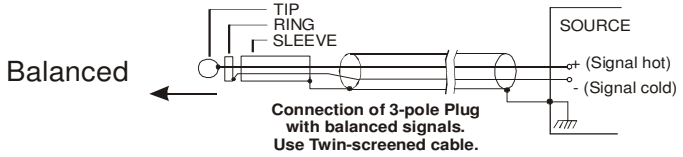

SLAVE I/O

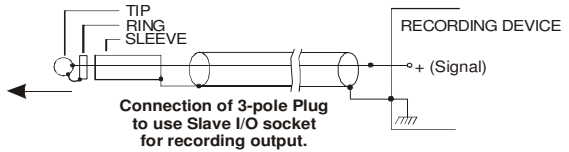

LOOP CONNECTOR

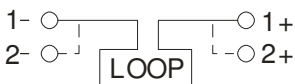
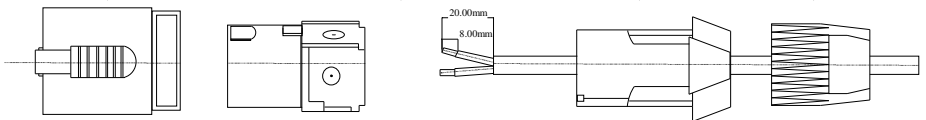

Refer to technical specifications for connection details

Block Diagram

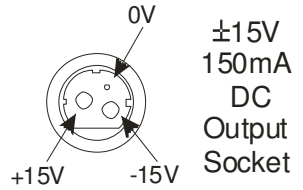
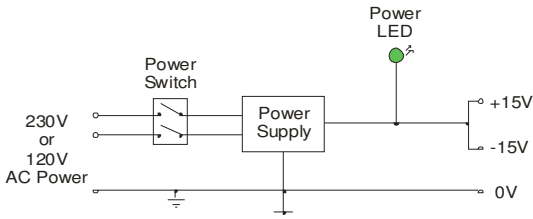
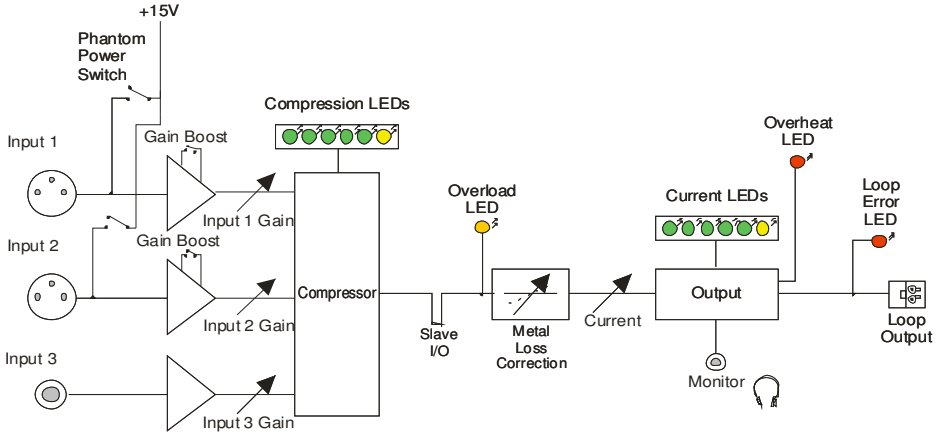

Use cable supplied.
Must be 3m or less.

INSTALLATION

Location

The unit may be free standing or 19" rack mountable using the rack 'ears' supplied. Fitting of the 'ears' is achieved by removing the two left hand side for the smaller 'ear' and all three right hand side panel screws for the larger 'ear'. The same screws are then re-used to secure the 'ears' in place. (A PH2 screwdriver will be required). For 19" rack mounting the four rubber feet must be removed.



The location must provide adequate ventilation for the unit.

An internal fan provides forced ventilation using air vents at the left side (intake) and rear (exhaust) of the unit. Both of these vents must be unobstructed for satisfactory cooling. If the unit is installed in an enclosed environment, sufficient airflow into the enclosure must be provided through vents fans or other means, such that the units exhaust air is not recycled to the inlet – causing a reduction in output current or OVERHEAT LED to be illuminated.

Contact Ampetronic for advice on cooling requirements for your installation.

Tools and Equipment

Small hand tools including a wire stripper and a small flat blade screwdriver will be required.

An ILR3 loop receiver or a magnetic field strength meter is vital to check that the loop system is providing the desired level of performance.

A pair of stereo headphones with a 3.5mm jack plug connection is also useful to monitor the loop signal.

System Requirements

The induction loop cable itself should be already installed according to the 'Designing Induction Loops' handbook, or as per specific design instructions provided by Ampetronic. As a result, a target current should be known, based on achieving acceptable field strength across the area to be covered.

It is important that the total resistance of loop and feed must be between 0.5Ω and 10Ω (at DC). If this is not achieved, the LOOP ERROR LED will become illuminated, and the amplifiers output will be disabled. See **Troubleshooting** section for details on how correct this, and get your system working.

The 'Designing Induction Loops' handbook contains more details on loop and feed cables. The correct design and positioning of the actual loop is vital for satisfactory system performance. If in doubt consult Ampetronic for advice.

See next page for connection and set-up.

Connection and Set-up

It is advised that the loop system is initially set up using a local audio source such as a CD player, which is not connected into any other system. This avoids the complication of ground loops and feedback etc, whilst the unit is set up.

The following procedure describes the installation of a stand alone ILD1000G, and does not incorporate connection of other ancillary units such as microphone pre-amps, mixing desks, or signal processing units.

1. Turn all controls fully anti-clockwise.
2. Connect the feed cable from the loop into the NL4 loop connector supplied as shown:

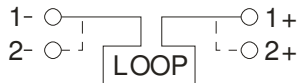

Note: Where using a perimeter loop (floor/ceiling level), the feed cable should be tightly twisted to avoid unwanted stray magnetic fields.

3. Connect the signal inputs appropriately:

Microphones: Suitable dynamic or condenser microphone with balanced cable feed. Select phantom power as required. Connect to INPUT 1 and INPUT 2 (with selector switch in the appropriate position) using a 3-pole XLR plug wired as per **Connections** drawing.

Line level signals: From other audio equipment such as PA system, mixing desk or CD player. Connect to INPUT 2 (with selector switch in the appropriate position) using a 3-pole XLR plug and INPUT 3 using a 3-pole balanced jack plug both wired as per **Connections** drawing.

You may use either or all three inputs.



Do not run input and output cables close together

The SLAVE I/O must **NEVER** be used as a separate input. It must only be used with Ampetronic signal processing equipment or for obtaining a signal for recording. See **Connections** for details.

4. Connect AC power to the ILD1000G. See points 6 and 7 in **Safety** section.
5. Switch ON. The POWER LED will flash for a few seconds whilst an internal self-test is performed and the loop resistance is tested. If both tests are successful, the POWER LED will illuminate continuously and the unit will be in an operational mode. If the POWER LED continues to flash, or the LOOP ERROR LED illuminates, consult the **Troubleshooting** section.
6. Select one input and apply a suitable audio signal (ideally a CD player

with music or continuous speech applied to INPUT 3, with no connection to INPUT 1 or INPUT 2). Turn the associated input control clockwise until two COMPRESSION LEDs are illuminated on the peaks of the signal.

7. Turn the CURRENT control clockwise until the target current is achieved – as indicated by the CURRENT LEDs. Note that consecutive LEDs illuminate at 3dB intervals. Headphones can be used with the MONITOR socket to listen directly to the loop current. If high frequency oscillation or low frequency hum is experienced, consult the **Troubleshooting** section.
8. The loop system should now be providing a magnetic field inside the area of the loop – use the ILR3 or field strength meter to examine its performance with respect to:
 - a. Magnetic field strength. This may vary across the coverage due to layout, metal loss and loop current.
 - b. Frequency response. Metal losses tend to increase with frequency, and may require the adjustment of the MLC control.

As a result of this analysis, adjust the CURRENT and set the MLC to achieve the best sound quality. This should result in adequate magnetic field strength and a level frequency response in order to satisfy IEC60118-4. Note: Do **NOT** adjust the MLC control whilst listening to the MONITOR socket as this will not give a true indication of the response of the actual loop.

Once the CURRENT and MLC controls have been adjusted to the correct level they should **NOT** need re-adjusting.

9. If not already done so, steps can now be taken to integrate the ILD1000G into a PA / mixer arrangement following standard audio techniques. If any unusual effects are experienced refer to the **Troubleshooting** section.

Note: Ideally, each input signal level should be set up to achieve 6dB (one LED) of COMPRESSION with the quietest level of input likely to be used. This will maximize the dynamic range of the system and ensure satisfactory performance.

10. Repeat the above procedure for each input used. When adjusting each input, make sure the signals are removed from the other inputs. This ensures that all signals are set to equivalent loudness and drive the compressor properly.

OVERVIEW

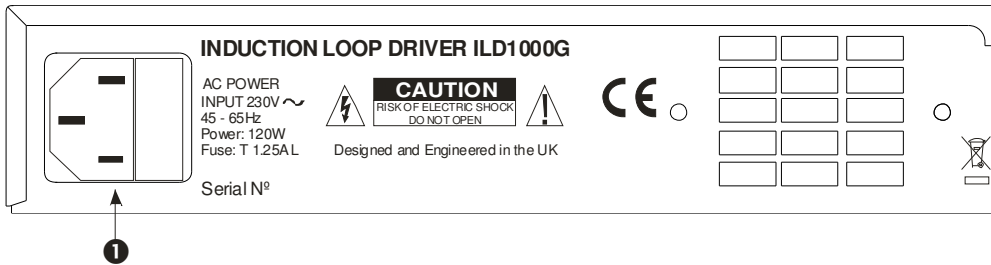
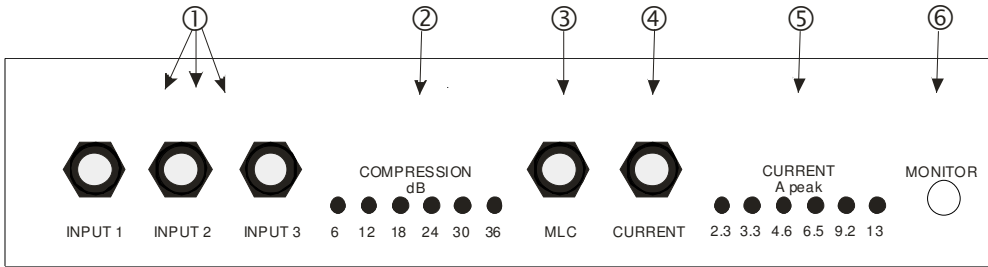

- ① **INPUT 1, INPUT 2 and INPUT 3:** Screwdriver adjustable controls which set the level of input signals.
- ② **COMPRESSION:** Shows the amount of gain reduction in decibels (dB) that is applied to the input signal(s).
- ③ **MLC:** Screwdriver adjustable control which compensates for the frequency dependant effects of metal.
- ④ **CURRENT:** Screwdriver adjustable control which sets the level of output current delivered into the loop.
- ⑤ **CURRENT:** Indicates the peak current delivered into the loop.
- ⑥ **MONITOR:** 3.5mm jack socket for use with stereo headphones to listen directly to the signal being delivered into the loop.
- ⑦ **OVERLOAD, OVERHEAT and LOOP ERROR:** Warning LEDs, see **Troubleshooting** section.
- ⑧ **POWER:** LED to indicate power is applied to the unit.
- ⑨ **I/O:** Power switch.

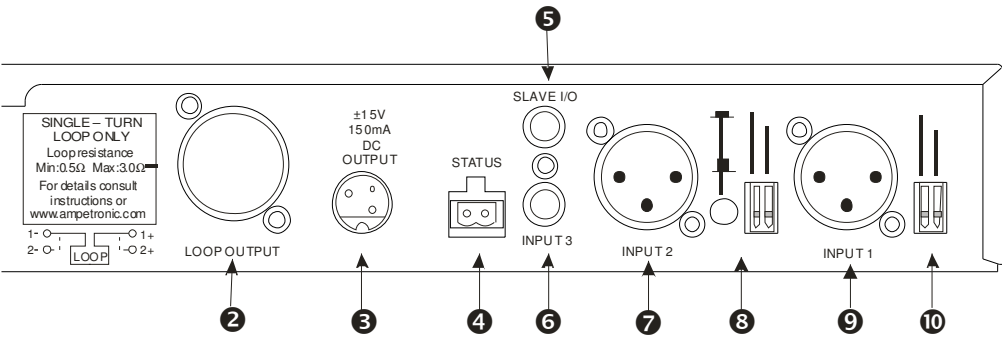

- ❶ **AC POWER:** Standard 3-pole IEC320 connector containing primary fuse for the unit.
- ❷ **LOOP OUTPUT:** Neutrik 'Speakon' High current connection to the loop cable.
- ❸ **±15V 150mA DC OUTPUT:** 3-pin mini DIN connection for ancillary units.
- ❹ **STATUS:** Connection to relay contacts providing remote fault indication
- ❺ **SLAVE I/O:** 3 pole 6.4mm jack insert point for use with ancillaries.
- ❻ **INPUT 3:** 3 pole 6.4mm jack socket for balanced line level inputs.
- ❼ **INPUT 2:** XLR socket for balanced MIC/line level signals
- ❽ **LINE/MIC:** Mode select switch for input 2.
GAIN BOOST: Gain selector switch for input 2 (ON = +15dB).
PHANTOM: Phantom selector switch for input 2.
- ❾ **INPUT 1:** XLR socket for balanced MIC signals
- ❿ **GAIN BOOST:** Gain selector switch for input 1 (ON = +15dB).
PHANTOM: Phantom selector switch for input 1.

TROUBLESHOOTING

POWER LED not illuminated

- Check that the power switch is toggled to the ON (I) position.
- Check fuse continuity. A 20mm fuse is incorporated into the AC POWER inlet. It is necessary to remove the power cord before extracting the fuse holder. Test the continuity of the fuse using a multimeter. A spare fuse is provided in the fuse holder

 Any replacement fuse **MUST** be of the same rating and type as printed on the rear of the unit.

POWER LED flashing continuously

Amplifier has failed self test and is in safe mode. No signal will be fed into the loop. Switch the unit off, remove all connections except the loop and power connections, turn all front panel controls to minimum and switch back on. If the problem persists, contact Ampetronic for advice.

COMPRESSION LEDs not illuminating

Check input connections.

Ensure that the appropriate front panel control (INPUT1, INPUT2 or INPUT3) is turned up. Check there is sufficient signal level for the required input.

CURRENT LEDs not illuminating

There are many possible causes for this:

- Check the COMPRESSION LEDs are illuminating.
- Check that the CURRENT control is turned up sufficiently.
- Check the LOOP ERROR, or OVERHEAT LEDs are not illuminated.
- Ensure the POWER LED is illuminated and not flashing.
- Remove any connection from the SLAVE I/O socket.
- Check that the loop cable is connected, terminated correctly and inserted into the LOOP OUTPUT socket.
- Check the loop is not open circuit, short circuit, or connected to earth (see instability or high frequency noise section of **Troubleshooting**)
- Switch the unit off and turn back on.

Note: You can listen to the actual loop signal by using a pair of headphones plugged into the monitor socket.

OVERLOAD LED illuminated

Indicates too much current is being delivered into the loop or that the output voltage is clipping. Occasional lighting of this indicator is normal on peaks of signal.

- Remove any connection to the SLAVE I/O.
- Turn down the CURRENT control to avoid running too much current or causing the output voltage to clip.
- Check the loop is not open circuit, short circuit, or connected to earth (see instability or high frequency noise section of **Troubleshooting**)
- Check the loop is within specified limits.

OVERHEAT LED illuminated

Indicates that the internal heatsink is too hot. Loop current is not delivered.

- Ensure that the unit is installed in a location with sufficient ventilation
- Check that nothing is blocking the free flow of air through the vents at the side and back of the unit.
- Check the loop is not open circuit, short circuit, or connected to earth (see instability or high frequency noise section of **Troubleshooting**)

LOOP ERROR LED illuminated

Indicates the loop cable connected to the unit is outside specification. It is important that the total resistance of loop and feed must be between 0.5Ω and 10Ω (at DC). If this is not achieved, the LOOP ERROR LED may illuminate and the amplifiers output will be disabled.

Important: Once the cause of any loop error has been established the unit will need to be restarted. Turn the power OFF - wait 5 seconds, and switch ON.

- Check that the loop cable is connected, terminated correctly and inserted into the LOOP OUTPUT socket. *Restart the amplifier as above.*
- Ensure the DC resistance is acceptable - between 0.5Ω and 10Ω . In all case the amplifier will need to be *restarted* once the problem is solved.

Note: Meter leads can easily measure 0.2Ω , and should be factored out.

- If the loop is open circuit - it may have been cut somewhere and will

require investigation and potentially re-laying.

- If the loop is high resistance $>10\Omega$ - check all connections and re-tighten, there may be something loose.
- Check for short circuits in the loop connector.
- If the loop is just very low resistance, fold a defined length (see below) of 0.5mm^2 cable in half and twist it together neatly – using a hand drill can be helpful. Coil this loosely on the forearm and bind it so that it does not come un-coiled. Then connect the two ends in series with the low resistance loop to ensure that the unit will always turn on, but the system performance is un-affected. 5m of 0.5mm^2 wire will add approximately 0.15Ω to loop resistance. Use an appropriate length to ensure the loop resistance exceeds 0.5Ω .

Note: High or low resistance loops can be encountered in a venue with a pre-installed loop, which was designed for use with an old loop driver which might be being replaced. Before using this loop ensure that the existing loop will allow the system to perform to an acceptable level by checking it's layout details in the 'Designing Induction loops' handbook.

Low magnetic field strength

Due to insufficient CURRENT or excessive metal loss.

May require a special loop design to achieve acceptable performance, contact Ampetronic for advice.

Instability or high frequency noise

1. It is possible for the loop cable to be grounded under fault conditions, resulting in instability which may sound like high frequency noise, buzz or whistling. The results of this type of fault are unpredictable and may appear as any combination of the front panel indication errors.

This fault is easy to determine. Simply unplug the loop cable from the amplifier and test with a resistance meter between either of the loop wires and a good earth point such as a metal radiator. There should be an infinitely high reading i.e. no connection at all. Any reading indicates a failure of the loop cable insulation and you will need to either repair or replace the loop cable.

2. Instability can be caused by using poor quality signal cables, long unbalanced (2-wire) signal runs to the inputs, or by running input cables in close proximity with the loop wire over an appreciable distance. Loop amplifiers are capable of delivering high currents at audio frequencies. If the loop cable is run close to sensitive signal cables it may be possible to induce a signal back into the input of the amplifier causing feedback. Cable runs and loop wires should be kept well apart from each other. To avoid interference maintain a

separation of at least 300mm.

3. Instability can cause the amplifier to run hot and may result in the OVERHEAT LED illuminating.

Interference

1. Background magnetic field signals or interference may be present in any location and may not be anything to do with the loop system. Monitor this with a loop receiver (such as an ILR3). If the interference is still present with the loop system switched off, then you need to locate and eliminate the source of the interference before switching the loop system back on.
2. Magnetic fields can induce currents into any low impedance electrical path or loop. Audio or video systems with multiple earths may experience pick up of the loop signal. Check entire sound system for evidence of loop signal, and trace source of pick up.
3. Under certain circumstances, the loop signal may appear as jagged lines or hum bars on a CCTV picture. This could be due to running CCTV (low impedance unbalanced 2-wire circuit) cables in close proximity to the loop cable. Separate the loop cables to reduce the effect.
4. Remote (and apparently unconnected) PA systems can sometimes pick up loop signals. This is usually because the loop cable becomes damaged (see point 1 of **Instability**) or induces signals into the remote system through long unbalanced cables. Always run long audio signal cables as 3-wire balanced circuits and keep away from loop cables.
5. See also point 1 of **Instability**

Failed AC power fuse in rear of unit

Unplug the loop and AC power supply from amplifier, and replace the failed fuse with the spare fuse in AC power input fuse tray.

Reconnect the AC power supply and switch on. If the fuse fails again, return the unit to Ampetronic for evaluation - it may well be covered under warranty, which will be invalidated by removing the cover. If the fuse does not fail a 'loop error' may be indicated, but shows that the unit is working correctly. Re-connect the loop and switch the power off then on again to reset loop error.

If the fuse fails when the loop is re-connected to the unit, then the loop could be shorted to electrical mains (and building) earth. This can happen even if no audio signal is present, as the short to earth is likely to cause an instability / oscillation / feedback condition to develop. A loop cable short to earth most commonly occurs where

flat copper tape is installed on a metal-clad raised access flooring system. If the insulation on the flat copper tape is abraded (for example by a piece of metal swarf trapped below the copper tape), the conductor could short to the earthed tiles.

When installing on raised access floors, it is advisable to insulate beneath the flat copper tape installation using Ampetronic PWT or similar tape.

The loop short to earth may only be completed when a person steps on the tape in the affected location, which can create significant difficulties when diagnosing the cause of fuse failure. Contact Ampetronic for further advice if a unit is suffering recurring but untraceable failure of the rear panel fuse.

ACCESSORIES

Details of all products and services provided by Ampetronic can be found at www.ampetronic.co

Wall mount brackets are available for mounting the amplifier on the wall with appropriate fixings

Microphone pre-amplifiers

Signal processing units are available for use with low spill array systems.

Input adaptors for a range of applications such as 100V line audio and low Z speaker systems are available.

TECHNICAL SPECIFICATIONS

INPUTS

Input figures quoted at maximum front panel gain control setting.	MIC		Line	
	Normal	Boost	Normal	Boost
INPUT 1; Balanced, XLR connector. 15V phantom Suitable source impedance Input impedance Sensitivity Overload	≤600Ω 1kΩ -55dBu -19dBu	≤600Ω 1kΩ -70dBu -34dBu	- - - -	- - - -
INPUT 2; Balanced, XLR connector. 15V phantom. Suitable source impedance Input impedance Sensitivity Overload	≤600Ω 8700Ω -55dBu -24dBu	≤600Ω 8700Ω -70dBu -39dBu	8700Ω -30dBu 1dBu	8700Ω -45dBu -14dBu
INPUT 3; Balanced line level. 6.4mm jack. Input impedance Sensitivity Overload	- - -	- - -	1MΩ -30dBu 5dBu	- - -
AC POWER; Standard IEC inlet Mains supply voltage Frequency Power Fuse Inrush current	230V (115V) 45–65 Hz 120 W (EN60065 test into square loop) T 1.25A L (T 2.5A L) - relevant approvals. 15A (30A)			

COMPRESSION (AGC)

Compression of signal in dB shown on six front panel LEDs Input range Output range Min. input level for AGC Attack time Decay time	>36dB ±1dB across input range Depends on input used (see sensitivity) 8ms 2s
---	--

OUTPUTS

Slave I/O; Insert point for connecting Ampetronic external processors. (out-tip, in-ring, sleeve-gnd). Source impedance Input impedance Output signal level Max cable length	220Ω 100kΩ 1.5Vpk 1m
LOOP OUTPUT; NL4 speakon (1+ & 2+ connected internally as are 1- & 2- to allow 'starquad' method of cable connection). Voltage Current into a single turn loop. Absolute max short term peak current. THD +N Frequency response (loop current) Metal Loss correction Current in Amps peak indicated via six LEDs at 3 dB intervals. PPM style processing for display Attack Decay	45V peak (31.8V _{RMS}) 13A peak (9.2A _{RMS}) >19A <0.2% @1kHz 80Hz to 6.5kHz ±1.5dB at low level Adjustable 0 to 3dB per octave (gain @1kHz remains constant) 4.7ms 1s

±15V DC OUTPUT; Power Mini DIN connector Max cable length	±15V @ 150mA max. 3m
Status Socket; The status socket consists of a pair of isolated contacts (plug supplied as standard). Amplifier or load fault Amplifier and load OK Contact rating Dielectric strength (coil – contact)	Open Closed DC 2A, 28V, 60W AC 0.5A, 125V, 60VA 1000Vac 50/60Hz

PROTECTION FEATURES

Clipping; Any clipping detected is shown on the front panel OVERLOAD LED. If clipping persists (>8s of continuous clipping) amplifier will shutdown and restart. Threshold	93% of peak output voltage (time delays applied to prevent nuisance tripping)
Output DC offset; If DC offset is detected amplifier will shutdown and restart threshold	±0.7V DC
Overheat; (internal heatsink); Output level reduction Output mute (illuminates OVERHEAT) Any of the above faults also cause the status relay contacts to open.	88 to 92°C (3dB max) 92°C (output returns at approx. 60°C)
Current limit; Also provides indication via OVERLOAD LED	Approx. 20A pk
Loop resistance testing; Checks the resistance of the load on startup is within limits. POWER LED flashes during this period. The LOOP ERROR LED illuminates and output maybe muted if load is outside limits Startup time Min resistance Max resistance	8s approx. 0.5Ω 10Ω
Cooling; internal variable speed fan. Intake on left side, exhaust on rear panel Fan noise Amplifier thermal emissions	33dBA at 1m no load 42dBA at 1m EN60065 test signal into std. square loop load 100W (EN60065 test into square loop)

PHYSICAL

Weight;	3.7kg
Dimensions; Width Height Depth	430 mm 44 mm 220mm
Environmental; Ingress Protection Operating temperature range Relative humidity	IP20 0 – 35°C 20 – 90%
Accessories supplied; Rackmount brackets Mains lead Loop connector Status socket connector	Long one for transformer (right hand) side Region specific Neutrik NL4 speakon Screw terminal plug

WARRANTY

This product carries a five year parts and labour warranty from date of shipment from Ampetronic. To qualify for the five year warranty, the product must be registered at www.ampetronic.co (products/warranty), without which the warranty will be valid for two years only.

The warranty could be invalidated if the instructions in this handbook are not followed correctly, or if the unit is misused in any way.

DECLARATION OF CONFORMITY

Manufacturer: Ampetronic Ltd.

Unit 2, Trentside Business Village
Farndon Road
Newark
NG24 4XB.

Declares that the product:

Description: Induction Loop Driver

Type name: ILD1000G

Conforms to the following Directive(s) and Norm(s):

Directive 2004/108/EC

EMC: EN55103-1 : 2009+A1:2012 Emission

EN55103-2 : 2009 Immunity

Directive 2006/95/EC

Safety: EN60065 : 2002+A12:2011

Directive 2011/65/EU RoHS

Date: January 2016

J.R. Pieters

Managing Director

Ampetronic Ltd.

blank

blank

blank