



S4.16

UHF
WIRELESS
SYSTEM

OPERATING MANUAL

CONTENTS

1. Introduction and Safety
2. Trantec S4.16 System Overview
3. Receiver Layout and Operation
4. Handheld Layout and Operation
5. Beltpack Layout and Operation
7. General Set-up, Operating Hints and Fault Finding
8. System Contents Description and System Part Numbers
9. Multi-Channel Configuration
10. Technical Specifications
12. Accessories/Warranty Terms

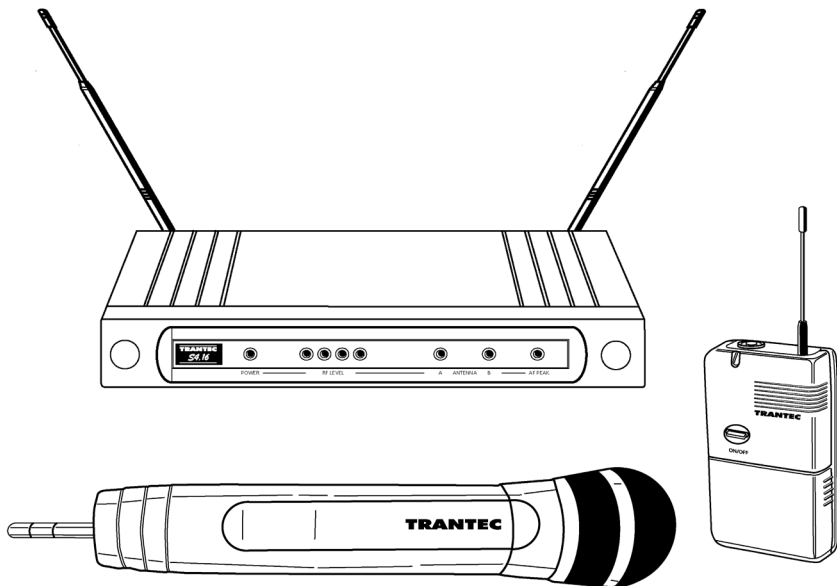

INTRODUCTION

The Trantec S4.16 Series represents Trantec's commitment to providing high-quality, affordable Wireless Audio Links using our considerable design expertise gained over many years as a leading edge manufacturer.

We would like to thank you for purchasing this product and would like you to spend a short time reading this *Operations Manual* so as to familiarise yourself with the features of the Trantec S4.16 series.

SAFETY

Our aim is to supply you with a product that provides you with countless hours of trouble free use.

In order to achieve these goals, we recommend the following:-

Keep the system away from direct sources of heat e.g. Central heating radiators, heaters and direct sunlight.

Should the Transmitters not be used for extended periods of time we recommend that the batteries are removed to avoid any potential leakage.

Keep the system clean by using a slightly damp cloth. Never use household cleaning agents or solvents.

Avoid using or storing the system in damp conditions.

Always use the AC power adaptor supplied with the Receiver and *never* remove the external covers of the equipment, so as to expose the electronics.

S4.16 SYSTEM OVERVIEW

The Trantec S4.16 is a high-quality UHF Wireless Microphone System. The S4.16 has many features including:-

- >> 16 User Selectable Channels.
- >> Diversity Receiver Operation - to minimise drop-outs.
- >> User Adjustable Audio Output Level - adjustable on both Jack and XLR outputs.
- >> User Adjustable RSSI/Squelch - enables the user to minimise external interference.
- >> Rear Mount Detachable Antennas.
- >> Includes 4 Licence Free Channels.
- >> 19" Rack Mount plate available.

THE S4.16 COMPRISES 2 BASIC DIFFERENT VARIATIONS:-

The Handheld System and the Beltpack Presenters/Instrument System.

The Handheld System comprises a fully integrated Handheld Microphone incorporating a Cardioid Dynamic Capsule and is most suited to General Vocal Applications.

The Beltpack System comprises a Beltpack Transmitter which is supplied with a small Lapel style clip-on Microphone and is ideally suited for General Presentation/ Theatre applications.

In addition the Beltpack Transmitter is supplied with an Instrument Cord. This cord enables the beltpack to be used with electric instruments e.g. Guitars and other high impedance applications.

S4.16 RECEIVER LAYOUT

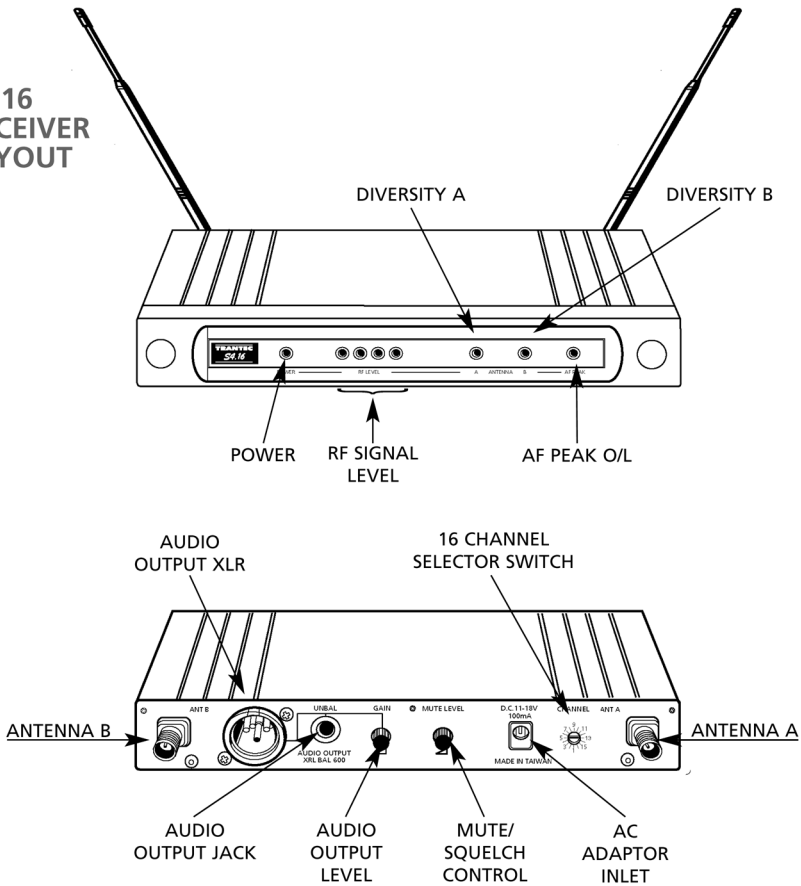

RECEIVER OPERATION

1. Connect the appropriate AC adaptor into the DC inlet as marked on the rear panel and observe the Supply indicator (green Led) lights up.
2. To provide best diversity operation, attach the antennae and angle them to form a "V" (as per illustration) ensuring they have a good line-of-sight view of the corresponding transmitter. i.e. Avoid placing large metallic objects in the transmission path.
3. Initially set the receiver AF gain control to its mid-position and connect the AF output from either the 1/4 inch Jack or XLR to your Mixing console or amplifier.
4. Select rear panel Channel Selector Switch (Small screw-driver adjust) to correspond to Transmitter setting. It is possible to select any of the 16 channels. (Factory set to position 1).

S4.16 HANDHELD LAYOUT

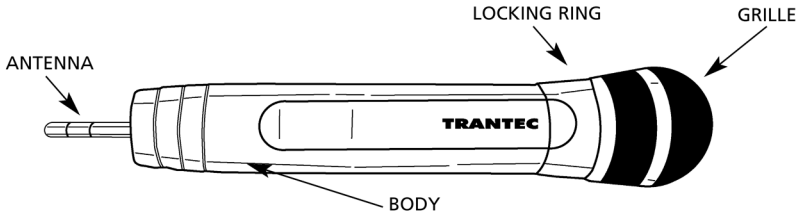

HANDHELD BATTERY INSERTION

1. Rotate the top collar locking ring in the direction indicated in the illustration and gently pull the body downwards.
2. Insert a 9V MN1604 (IEC 6 LR61) PP3 type alkaline battery, being sure to observe the correct polarity as marked.
3. Gently slide the body upwards and lock.

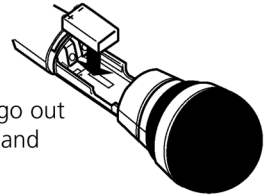
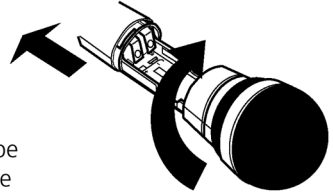

Note: Should the Red battery status Led Indicator go out during operation, this indicates a flattened battery and that it should be changed.

CHANNEL SELECTION. (Small screw-driver adjust)

With the Transmitter in the OFF position select a channel to correspond with the Receiver. It is possible to select any of the 16 channels.
(Factory set to position 1).

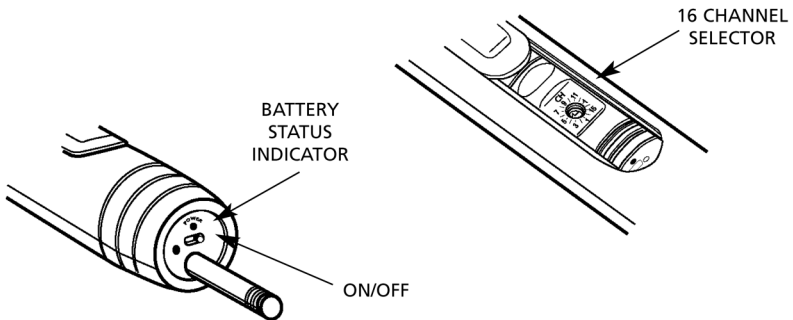

Note: If the Transmitter Active Channel has been changed whilst in the **ON** position, it must be turned **OFF** and then **ON** again to complete selection.

S4.16 BELTPACK LAYOUT

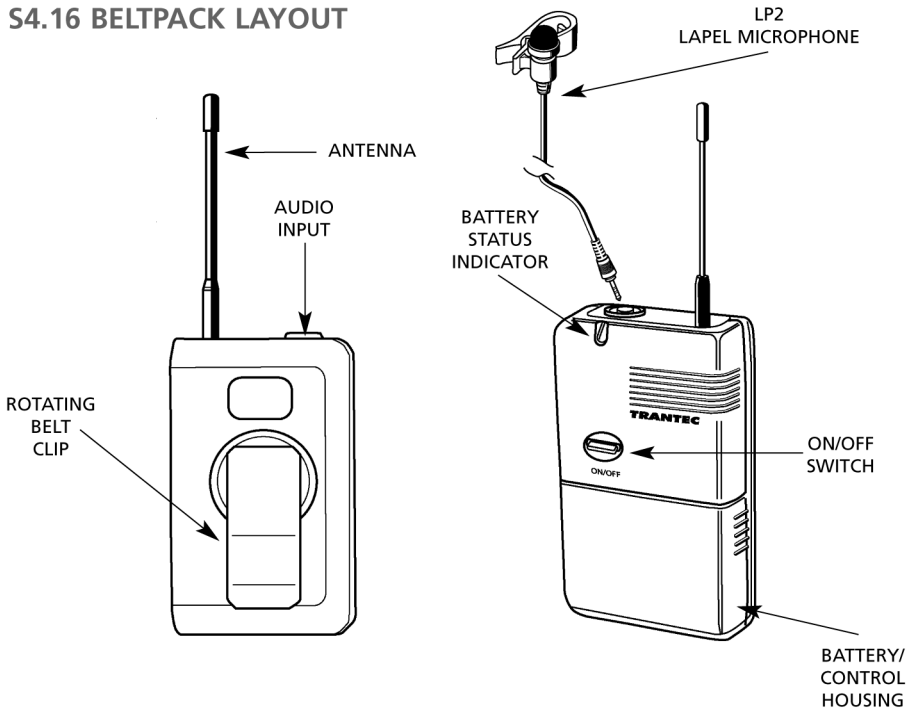

BELTPACK BATTERY INSERTION

1. Slide the battery compartment to the rear and hinge upwards to expose the battery.
2. Insert a 9V MN1604 (IEC 6 LR61) PP3 type alkaline battery, being sure to observe the correct polarity as marked.

Note: Should the Red battery status Led Indicator go out during operation, this indicates a flattened battery and that it should be changed.

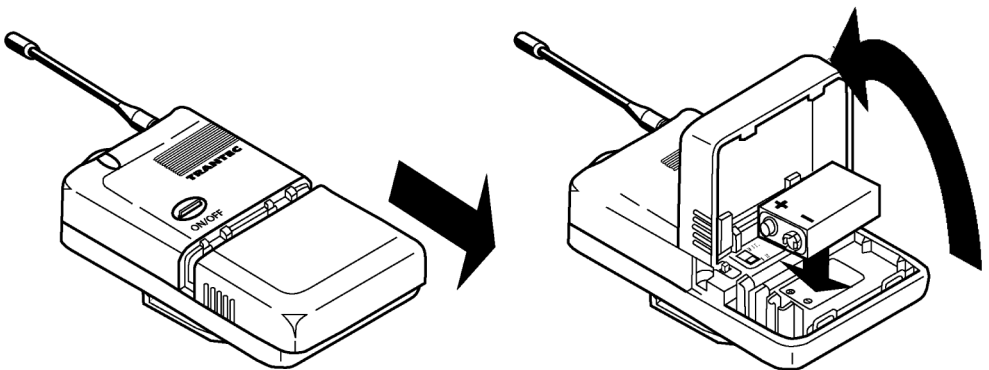

MICROPHONE CONNECTION

1. Connect small lapel-type microphone into the corresponding 3.5mm Top Panel Socket.
2. Ensure that the Battery Compartment **MIC/INST** switch is set to **Mic** position.
3. Clip the microphone to your clothing (normally Tie or Jacket Lapel). Route the mic cable so as to avoid undue strain or friction. Try and keep the mic cable away from the **ANTENNA**

The microphone supplied with the S4.16 has an Omni-directional response, which means it will pick up sounds from all directions. In view of this we recommend that the microphone is placed as close as possible to the required sound source.

INSTRUMENT CONNECTION

1. Connect the supplied Instrument cord into the corresponding 3.5mm Top Panel Socket.
2. Ensure that the battery compartment **MIC/INST** switch is set to **INST** position

BELTPACK GAIN CONTROL ADJUSTMENT. (Small screw-driver adjust)
If required adjust the Transmitter AF gain control so the signal only very occasionally allows the **Red AF O/L Peak Led** on the receiver to light.

CHANNEL SELECTION (Small screw-driver adjust)

With the Transmitter in the **OFF** position, select a channel to correspond with the Receiver. It is possible to select any of the 16 channels.
(Factory set to position 1).

Note: If the Transmitter Active Channel has been changed whilst in the **ON** position, it must be turned **OFF** and then **ON** again to complete selection.

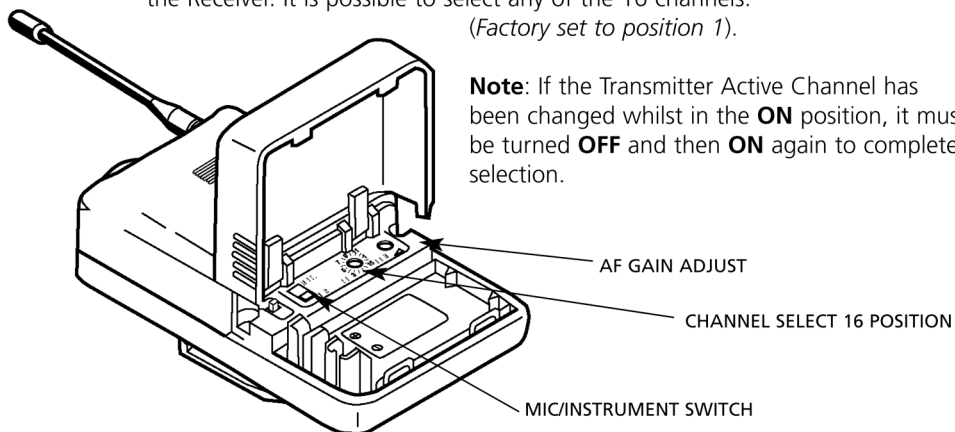

GENERAL SETUP AND OPERATING HINTS

1. **DISTANCE.**

To maximise operating distance (approximately 100m). We recommend you follow the guidelines below.

- a. Ensure good line of sight between Transmitter and Receiver. Do not place large obstructions between receiver and transmitters e.g. Concrete walls, large metal obstructions. In addition keep the receiver away from metallic beams and obstructions as these can adversely affect the Antenna Pick-up Pattern and induce interference.
- b. Always ensure that the Transmitter is at least 3m (10 feet) away from the Receiver.
- c. Conduct a "Walk test" which involves you moving the Transmitter in the area where transmission is required whilst noting the received RF signal strength on the receiver bargraph. Reception is best with all 4 Leds lit.
- d. Never position the Transmitter Antenna directly against the body or hand. This will reduce the operating range considerably.

2. **SQUELCH/RSSI SET UP.**

The S4.16 incorporates a Fixed Noise Squelch and a variable "Received Signal strength" Mute Control on the rear panel of the Receiver. This function is to reduce or eliminate the effect of interference from outside sources.

Note: Trantec cannot guarantee multi-channel compatibility with other brands/make of product.

To adjust follow these steps:

- a. Turn off the Transmitter and note if any interference is present by monitoring the Receiver RF Bargraph or Audio Output.
- b. Turn the Squelch Control clockwise until the interference disappears. In extreme cases it may not be possible to remove the unwanted interference and in this case it is recommended you try an alternative channel.

Note: the Squelch Control affects the operating range of the system and with the Squelch set to maximum, the range will be significantly reduced.

3. **RECEIVER AF GAIN ADJUST.**

The S4.16 receiver gain is continuously adjustable between Mic and Line level.

Should the receiver signal be too high it will distort your mixer/amplifier. If the signal is too low the result will be an increase in general background noise.
Adjust this control to achieve the best signal quality.

4. BATTERY INFORMATION.

Please note that this product is designed to be used with a 9V Alkaline battery. Should you use a rechargeable cell, be sure not to force it into the battery compartment as some types can be considerably larger than standard types and note that the operation time will be much reduced.

5. LOW-BATTERY STATUS INDICATOR ON TRANSMITTERS.

In normal circumstances, with the use of an Alkaline 9V battery, the Transmitters should provide approximately 10hrs of continuous use. Should the Battery indicator go out, it is advisable to change the battery as soon as possible.

FAULT-FINDING.

In the event of a problem it is worth checking the following check list.

1. No RF Signal Indication on Receiver!

- a. Are the Receiver and Transmitter on the same channel?
- b. Is the battery fresh in the Transmitter and the battery indicator lit?

2. No Audio Signal!

- a. Is the AF Gain Control set correctly on the Receiver?
- b. Is the Squelch Control set correctly (Normally mid-position)?
- c. Is the MIC/INST switch in the correct position on the Beltpack?

S4.16 SYSTEM PACKAGE CONTENTS

S4.16M SYSTEM:

S4.16RX	Receiver
S4.16LTX	Beltpack Transmitter
PSU	Mains AC adaptor
LP2	Lapel type microphone
GC2	Instrument cable
S4.16BK	Instruction manual.
UK ,US or EURO	Power supply

S4.16L SYSTEM:

S4.16RX	Receiver
S4.16MTX	Handheld Transmitter
PSU	Mains AC adaptor
MA2	Microphone stand mount/adaptor
S4.16BK	Instruction manual.
UK ,US or EURO	Power supply

MULTI-CHANNEL CONFIGURATION WITH S4000ADU

1. MULTICHANNEL OPERATION OF THE S4.16.

The S4.16 is designed for simultaneous use of several systems.

- a. Ensure each system is assigned a different operating channel. The channels are adjusted as per the illustrations on page 4 & 6. It is important that each Transmitter/Receiver combination has its own unique channel numbered 1-16.
- b. Try to ensure that each Transmitter is separated by 0.5m (1.5 feet) during operation.

It is recommended that for systems with 4 or more channels the **Trantec Antenna Distribution Amplifier S4000ADU** is used together with the **S4.16** Rackmount kit, this allows the use of only 1 set of antennas to feed several receivers which are then fixed onto 19" 1U rack trays in multiples of 2. Each **ADU** is capable of driving 4 units simultaneously with a separate output for additional **S4000ADU** units. Below is a typical 8 channel installation. Each **S4000ADU** comes complete with all necessary connecting leads for 4 channels.

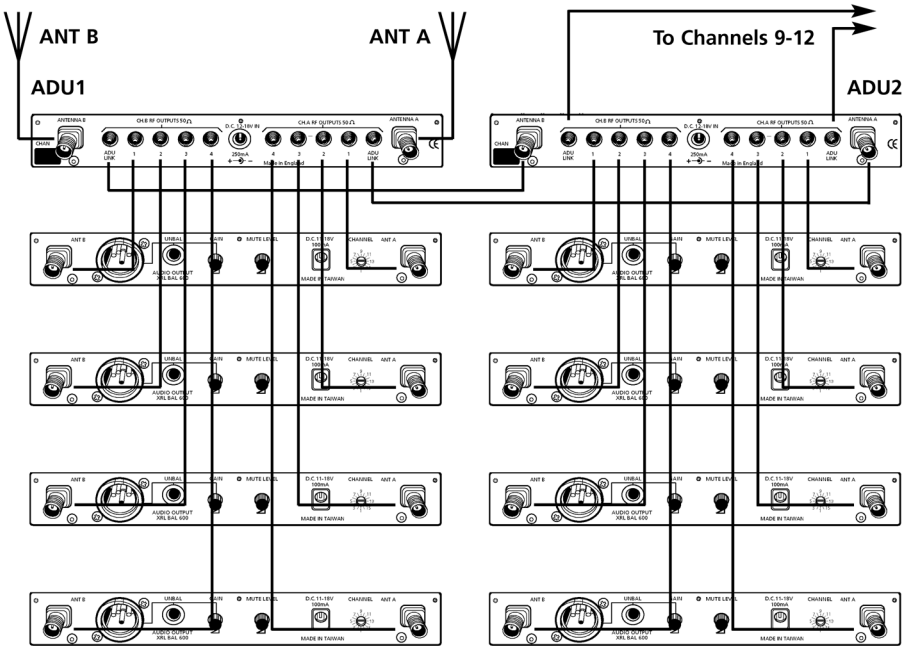

Note: The Transmitter only changes Active Channel when turned **off** and then **on** again.

2. OPTIMUM FREQUENCY CONFIGURATION

For Band EA 854-865 MHz

Up to 4 Frequency Set		Up to 8 Frequency Set		Up to 12 Frequency Set	
Position	Frequency	Position	Frequency	Position	Frequency
1	863.150	1	863.150	1	863.150
2	863.725	2	863.725	2	863.725
3	864.150	3	864.150	3	864.150
4	864.850	4	864.850	4	864.850
		6	855.900	5	854.900
		8	856.575	6	855.900
		12	859.500	8	856.575
		16	861.750	9	857.950
				12	859.500
				13	860.400
				14	860.900
				16	861.750

For Band UH 719-744 MHz

Up to 4 Frequency Set		Up to 8 Frequency Set		Up to 12 Frequency Set	
Position	Frequency	Position	Frequency	Position	Frequency
1	742.075	1	742.075	1	742.075
2	742.800	2	742.800	2	742.800
3	743.300	3	743.300	3	743.300
4	743.975	4	743.975	4	743.975
		5	719.125	5	719.125
		7	722.700	6	720.475
		9	726.425	8	725.025
		15	739.525	9	726.425
				11	730.500
				13	732.925
				14	733.825
				15	739.525

Trantec recommend that 12 frequencies is the largest set that can be used with the S4.16

TECHNICAL SPECIFICATIONS:-

OVERVIEW.

Fully synthesised 16 channel PLL Quartz Controlled FM Wireless Microphone System incorporating a Dual Conversion Diversity Receiver with Integral Audio Dynamics Processor.

OPERATING FREQUENCIES

SET 1: 863.150 863.725 864.150 864.850 854.900 855.900 856.175 856.575
(EA) 857.950 858.200 858.650 859.500 860.400 860.900 861.200 861.750

SET 2: 742.075 742.800 743.300 743.975 719.125 720.475 722.700 725.025
726.425 728.525 730.500 731.350 732.925 733.825 739.525 741.025

AF S/N RATIO: > 100dBA

AF FREQUENCY RESPONSE: Handheld 80Hz – 16KHz +/- 3dB.
Beltpack 60Hz - 16KHz +/- 3dB

AF THD: less than 1%

OPERATING TEMPERATURE RANGE:
-10° - +45°C / 95 relative humidity.

RECEIVER

OPERATING VOLTAGE: 12V @ 100mA

FIRST IF FREQUENCY: 55.875MHz

SECOND IF FREQUENCY: 10.700MHz

AF OUTPUT: Variable to +10dBu unbalanced via 1/4 inch mono Jack socket.
+16dBu Balanced via XLR 3F connector Pin 2 +.

INDICATORS: 4 position RF Bargraph, AF peak (overload), Power, Diversity A/B.

CONTROLS: Channel select, AF output, Squelch.

DIMENSIONS: 35 x 213 x 98mm.

WEIGHT: Approx 580g

HANDHELD TRANSMITTER

OPERATING VOLTAGE:	9V @ <50mA.
OPERATING TIME:	approx 10 hours.
OUTPUT POWER:	10mW max.
CONTROLS:	Frequency select, On-off switch.
INDICATORS:	Battery status Led.
TRANSDUCER TYPE:	Dynamic with Cardioid pattern.
DIMENSIONS:	280 x 50mm max. (including grille)
WEIGHT:	Approx 210g

BELTPACK TRANSMITTER

OPERATING VOLTAGE:	9V @ <50mA.
OPERATING TIME:	approx 10 hours.
OUTPUT POWER:	10mW max.
CONTROLS:	Frequency select, On-off switch, Lapel/Instrument switch, Gain adjust.
INDICATORS:	Battery status Led.
CONNECTORS:	AF input via 3.5mm socket. Tip = Audio. Ring + sleeve = Gnd.

LP2 LAVALIER MICROPHONE:

	Back electret condenser microphone with omni-directional pattern.
DIMENSIONS:	60 x 100 x 30mm mm including belt clip.
WEIGHT:	Approx 90g
TYPE APPROVALS:	ETSI 300-422, FCC pt 74 h.

S4.16 SYSTEM ACCESSORIES

>> S4000PSU	5 –way power supply for 4 x S4.16 Receivers + ADU
>> S4000ADU	Antenna Distribution Unit for S4.16 Receivers
>> ACC/S4.16	19” Rack mount kit for 2 x S4.16 Receivers
>> ANT/UHF-RA-1	Spare antenna for S4.16 Receiver
>> ANT/UHF-GP	Ground plane antenna
>> ACC/S4.16RD	Bracket for remote dipole antenna mounting
>> LD/N-TNC-ANT	Cable: 5M RG213 N type to TNC
>> LD/N-TNC-10M	Cable: 10M RG213 N type to TNC
>> LD/SMC-TNC	Cable: Receiver > ADU
>> LD/SJ-JAC	Instrument cable: screw jack to 1/4in jack
>> S4.16LTX-EA	S4.16 Beltpack Transmitter
>> S4.16MTX-EA	S4.16 Handheld Transmitter
>> S4.16RX-EA	S4.16 Receiver
>> ANT/4.4LTX-EA	S4.4/4.16 Beltpack Antenna
>> ANT/4.4MTX-EA	S4.4/4.16 Handheld Antenna
>> PS/S115	Power Supply 220v >15vdc (UK 3 pin)
>> PS/S115EU	Power Supply 220v >15vdc (European 2 pin)
>> MIC/LP2	Lavalier mic with screw jack
>> ACC/LP2-TC	LP2 Tieclip
>> MIC/SJ10	Head-worn noise cancelling microphone - Omni
>> MIC/SJ22-B	Head-worn Hi-Q microphone – black
>> MIC/SJ22-P	Head-worn Hi-Q microphone – pink
>> MIC/SJ212-B	Lapel Hi-Q microphone – black
>> MIC/SJ212-P	Lapel Hi-Q microphone – pink
>> MIC/SJ46Y	Aerobic headset microphone – yellow
>> MIC/SJ66	Aerobic headset microphone – black
>> MIC/SJ33	Head-worn microphone
>> MIC/SJ46B	Aerobic headset microphone - blue

DECLARATION OF CONFORMITY:

This equipment is in compliance with the essential requirements and other relevant provisions of Directives 1999/5/EC, 89/336/EC or 73/23EC.

More information available at: www.trantec.co.uk

GUARANTEE:

All Trantec products are guaranteed for a period of one year from date of purchase against defects in materials and workmanship. In the event of a claim under guarantee the system should be returned to your dealer in its original packaging and with proof of purchase. Defects caused by modification, mis-use or accident are not covered by this guarantee. E&OE Due to our continual policy of research and development we reserve the right to alter specifications without prior notice.

10/06